

POS Keyboard

PKB-111/118 Series



TYSSO®

Insist on the Best

PKB
Series



Durable, Quality, Ergonomic, Elegant design

Key configuration technique,
Multi-Layer Programming capability

FEATURES

- 111/118 keys programmable keyboard with Full-Height Cherry keyswitch
- True keyboard wedge function; operating with or without the normal computer keyboard
- No TSR program required; avoids application software crashes
- Each key can be programmed up to 255 bytes, depending on the size of the built-in non-volatile memory
- Multi-Layer programming capability
- Optional MCR available in various track combinations

SPECIFICATIONS

Model Number	PKB-111	PKB-118
Electronics		
Power supply	+5VDC±10%	+5VDC±10%
Current Consumption	350mA	350mA
Interface	AT, PS/2	AT, PS/2
Mechanical		
Total key switch	112	119
Total travel	4±0.4mm	4±0.4mm
Pre-travel	2±0.6mm	2±0.6mm
Peak load before make	60±20cN	60±20cN
Others		
Storage Temperature	-20°C to +70°C	-20°C to +70°C
Operating Temperature	0°C to +50°C	0°C to +50°C
Operating Humidity	0% to 95%	0% to 95%
Dimensions	75(L)x176(W)x47(H)mm	75(L)x176(W)x47(H)mm
Weight	1800 (g)	1800 (g)
Optional		
Double POS keycaps with transparent keycap covers		
Quad POS keycaps with transparent keycap covers		
Paper legends (Color can be on demand)		
Color keycaps (Color can be on demand)		

DIMENSIONS:

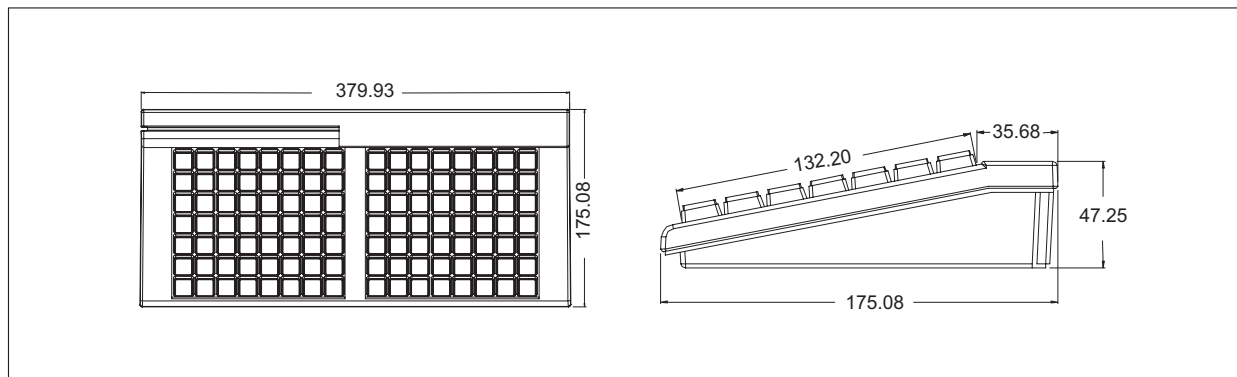

Manufacturer
FAMETECH INC.
 2F, No. 165, Sec. 2, Ta-Tung Rd.,
 Hsi-Chih 221, Taipei Hsien, Taiwan
 Tel : 886-2-8692-6300
 Fax: 886-2-8692-6301
 E-mail: tyssso@ms6.hinet.net
 URL: <http://www.Famotech.com.tw>

